

NTU NUMERICAL SENSOR

User manual



CONTENTS

1. GENERAL	3
2. CHARACTERISTICS	4
2.1 Technical characteristics.....	4
2.2 CE compliance.....	5
3. DESCRIPTION.....	6
3.1 Product overview.....	6
3.2 Applications.....	6
3.3 Construction and dimensions.....	6
3.4 Communication.....	7
3.4.1 Modbus RTU registers.....	7
3.4.2 SDI12 frame.....	7
3.5 Sampling rate.....	8
4. INSTALLATION.....	8
4.1 Sensor installation option	8
4.1.1 Accessories for immersion installation.....	8
4.1.2 Accessories for PVC pipe-mounting.....	11
4.1.3 Accessories for stainless steel pipe-mounting.....	12
4.2 Installation of the sensor in the accessories of assembly.....	13
4.2.1 Insertion in a pole.....	13
4.2.2 Insertion into the PVC in-pipe mounting system.....	14
4.2.3 Insertion into the Stainless steel in-pipe mounting system.....	15
4.3 Electrical connections.....	15
5. STARTUP AND MAINTENANCE.....	16
5.1 Initial startup.....	16
5.2 Calibration.....	16
5.2.1. Calibration in NTU.....	17
5.2.2. Calibration in mg/L.....	17
5.3 Maintenance.....	18

1. General

In order to maintain and ensure the good working order of the NTU sensor, users must comply with the safety precautions and warnings featured in this manual.

Assembly and activation:

- Assembly, electrical connection, activation, operation and maintenance of the measuring system must only be carried out by specialist personnel authorized by the user of the facilities.
- Trained personnel must be familiar with and comply with the instructions in this manual.
- Make sure the power supply complies with the specifications before connecting the device.
- A clearly-labeled power switch must be installed near the device.
- Check all connections before turning the power on.
- Do not attempt to use damaged equipment: it may represent a hazard and should be labeled as faulty.
- Repairs must only be carried out by the manufacturer or by AQUALABO CONTROL's after-sales service department.

➤ Marking on the body of the sensor:

The marking on the body of the sensor indicates the serial number of the sensor (for the traceability) and the LOGO CE.



1	Datamatrix (contains the serial number)
2	Serial number PHEHT sensor : SN-PNEPX-YYYY X : version YYYY : number
3	CE mark

2. Characteristics

2.1 Technical characteristics.

The technical characteristics can be modified without advance notice.

pH	
Measure principle	Turbidity : Diffusion IR at 90° Temperature : NTC
Measure ranges	0 to 4000 NTU in 5 ranges: <ul style="list-style-type: none"> ▪ 0 – 50 NTU ▪ 0 – 200 NTU ▪ 0 – 1000 NTU ▪ 0 – 4000 NTU ▪ AUTOMATIC 0 to 4500 mg/L Calibration : Range 0-500 mg/L according to NF EN 872 Range >500 mg/L according to NF T 90 105 2
Resolution	0,01 to 1 NTU - mg/L
Accuracy	< 5% of the reading
Temperature	
Technology	NTC
Range	0,00 °C to + 50,00°C
Resolution	0,01 °C
Accuracy	± 0,5 °C
Response time	< 5 s
Storage temperature	0°C to + 60°C
Sensor	
Dimensions	Diameter : 27 mm; length : 170 mm
Weight	300 g (sensor + cable 3 meters)
Wetted material	Head of the sensor : PVC, Body : DELRIN, Optical part : Quartz, Cable : polyurethane jacket Steam gland : Polyamide
Safeway	The optical windows are vulnerable to: <ul style="list-style-type: none"> - chemicals (organic solvents, acids and strong bases, peroxide, hydrocarbons), - mechanical treatments (impact, abrasion).
Maximum pressure	5 bars
IP classification	IP68
Connection	9 armoured connectors, polyurethane jacket, bare-wires or waterproof Fisher connector
Sensor cable	Standard : 3, 7 and 15 m (other length on request). 100 m Max. Up to 100 m with junction box.
Communication – Power supply	
Signal interface	Modbus RTU RS-485 and SDI-12
Power requirements	5 to 12 volts for cable 0-15 m 7 to 12 volts for cable >15 m Max. 13.2 V
Consumption	Standby : 40 µA Average RS485 (1 measure/seconde) : 820 µA Average SDI12 (1 measure/seconde) : 4,2 mA Current pulse : 500 mA Heating time : 100 mS Protection against the inversions of polarity

2.2 CE compliance.

Pursuant to the article 11 of the directive 89 / 336 / EEC relative to the electromagnetic compatibility.

We declare that the digital sensor of the range DIGISENS sensor NTU was tested and declared in compliance with the European standards :

Standard tests : EN 61326-1 edition 2013

Emission - EMC EN 55022 Class B

Immunity - EN 61000-4-3 A

EN 61000-4-2 B

EN 61000-4-6 A

EN 61000-4-4 B

Shone disturbances : EN 55011B

Identification of the measurement process : composed of :

1- one probe

2- Ponsel's cable.

EN 61000-4-5 Not concerned for sensors with a cable lower or equal to 30 M

Commercial name : DIGISENS range

Manufacturer AQUALABO CONTRÔLE –Ponsel Mesure
35 Rue Michel MARION
56850 CAUDAN

Responsible UE : AQUALABO CONTRÔLE – Ponsel Mesure
35 Rue Michel MARION
56850 CAUDAN

3. Description.

3.1 Product overview

The turbidity measurement according to DIN EN ISO 7027 is a tried and tested method for monitoring waters with low to strong turbidity.

The measuring principle of the NTU turbidity sensor is based on an infrared light measurement according to the 90° scattered light method. Thanks to the light measurement at a wavelength of 880 nm and the wide measuring range of 0 to 4,000 NTU, the sensor can be used in an array of water and wastewater treatment applications, e.g. for monitoring the water quality, detecting filter leaks, and for wastewater final inspection.

Apart from the turbidity value, the sensor also measures the medium temperature and Suspended Solid in mg/L (0-4500 mg/L).

The NTU sensor stores its calibration data and history directly in the sensor electronics. This means that it can be used quickly anywhere without the need for constant recalibration.

The sensor is characterized by its slim and robust design.

Suitable fittings are required for the installation of the sensor, e.g. in order to prevent the influence of extraneous light and any possibly resulting measurement errors. Corresponding immersion, suspended, and flow fittings are available.

3.2 Applications

The compact and robust sensor is particularly well suited to the following typical areas of application:

- Drinking water treatment
- Water protection
- Fish farming companies
- Municipal and industrial sewage treatment plants
- Process engineering plants

3.3 Construction and dimensions.

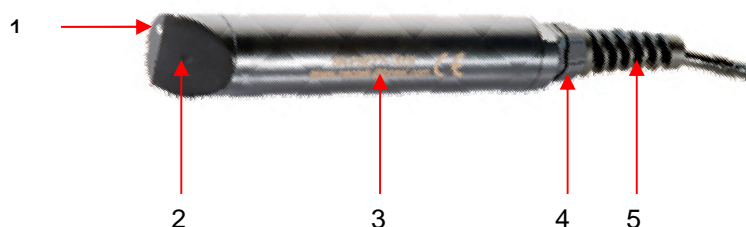

- (1) Temperature sensor
- (2) Optical window
- (3) Sensor body with measurement electronics
- (4) Cable bushing
- (5) Securely connected connection cable

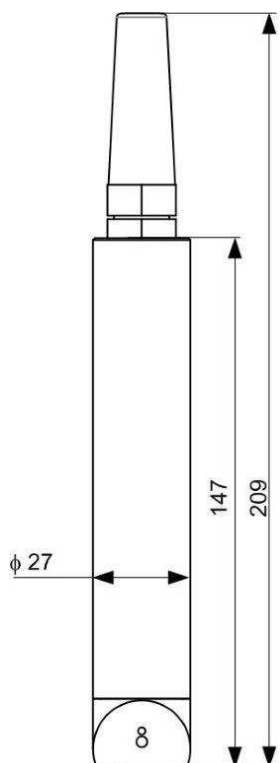

3.4 Communication.

3.4.1 Modbus RTU registers.

The link protocol must correspond to MODBUS RTU.

See document:

- Modbus_over_serial_line_V1_02.pdf
- Modbus_Application_Protocol_V1_1a.pdf
- Modbus memory for PONSEL digital Sensors :
SENSOR_TramesCom_xxx_UK.xls (refer to <http://www.ponsel-web.com/>)

The Modbus memory plane is identical for each parameter of the Sensors.

The Modbus protocol for the Sensors allows you to measure the parameter (+ temperature) of the Sensor and to calibrate the parameter (+ temperature). Furthermore, there are certain numbers of functions such as:

- Select the averaging value
- Read the Sensor description
- Return to default coefficients
- Modify the Sensor address
- Information on measures conducted (Out Of Specification measures, measures in progress, etc.).
- Date and name of the operator who performed the calibration
- etc.

To have more information on the open PONSEL's Modbus protocol please consult the last version of the following documents :

- the pdf file : Modbus_SpecificationsVxxx-EN
- the excel file : Digital sensor Frame_XXX_UK

3.4.2 SDI12 frame.

A list of SDI12 registers is available for network communication. Refer to <http://www.ponsel-web.com/> for more information.

3.5 Sampling rate

NTU sensors do not carry out any continuous measurements but it is possible to have a measure all 500 mS.

4. Installation.

4.1 Sensor installation option

For the installation of the sensors in condition of immersion or in-pipe insertion, we advise to use accessories adapted and proposed by AQUALABO CONTRÔLE.

4.1.1 Accessories for immersion installation.

In immersion condition, it is necessary to maintain the sensor by the body and not to leave the sensor suspended by the cable at the risk of damaging the sensor

AQUALABO CONTRÔLE proposes a range or pole (short and long version) in order to install the sensor in open basins. It can be positioned a considerable distance from the basin edge with the bracket suspended on a chain, for example.

Please note the following when planning your set-up:

- The fitting must be easily accessible to allow the sensor or the fitting itself to be maintained and cleaned regularly
- Do not allow the fitting (and thus also the sensor) to swing against and hit the basin edge
- When working with systems involving pressure and/or temperature, ensure that the fitting and sensor meet all relevant requirements
- The system designer must check that the materials in the fitting and sensor are suitable for the measurement (chemical compatibility, for instance)

Material	PVC
Admissible temperature	0 to 60 °C
Pressure max.	5 bars

➤ **Short pole**

The short pole is available in 2 versions :

- **version with elbowed shutter.** The nozzle of support is included in the offer.

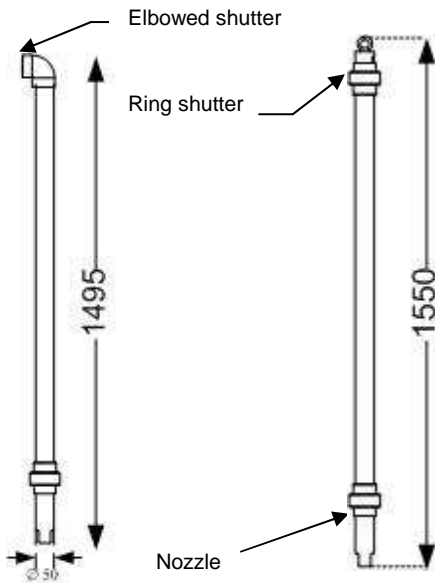

PF-ACC-C-00266	STRAIGHT SHORT POLE FOR OPTOD SENSOR (1495 mm, ELBOWED SHUTTER)
PF-ACC-C-00267	STRAIGHT SHORT POLE FOR PHEHT SENSOR (1495 mm, ELBOWED SHUTTER)
PF-ACC-C-00268	STRAIGHT SHORT POLE FOR C4E/NTU SENSOR (1495 mm, ELBOWED SHUTTER)

- **version with shutter for mounting with chain** The nozzle of support is included in the offer.

PF-ACC-C-00269	STRAIGHT SHORT POLE FOR OPTOD SENSOR (1550 mm, RING SHUTTER)
PF-ACC-C-00270	STRAIGHT SHORT POLE FOR PHEHT SENSOR (1550 mm, RING SHUTTER)
PF-ACC-C-00271	STRAIGHT SHORT POLE FOR C4E/NTU SENSOR (1550 mm, RING SHUTTER)

➤ **Long pole**

The long poles are available in elbow version, for installations in aeration basin, and straight, for applications in open channel. Every pole is equipped with an elbowed shutter and with waterproofness joints. The lower part includes a nozzle which is adapted to the sensor what assures its mechanical support.

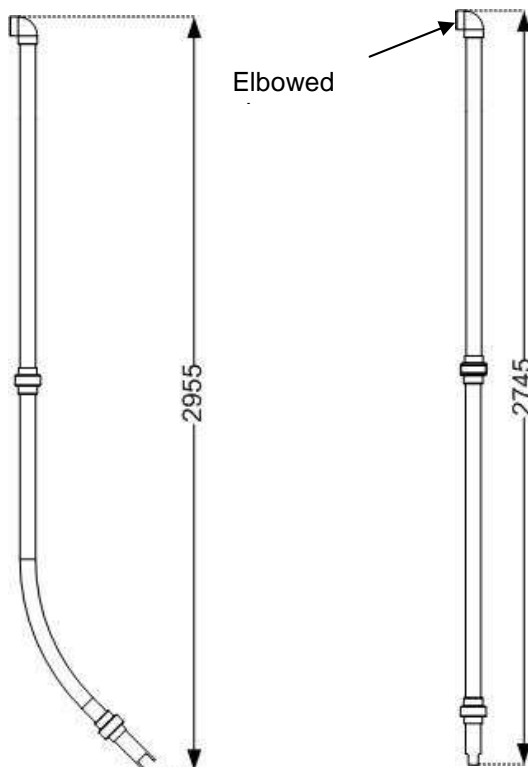

- **Elbowed pole with elbowed shutter**

PF-ACC-C-00230	90° ELBOW LONG POLE FOR OPTOD SENSOR (2955 mm, ELBOWED SHUTTER)
PF-ACC-C-00261	90° ELBOW LONG POLE FOR PHEHT SENSOR (2955 mm, ELBOWED SHUTTER)
PF-ACC-C-00262	90° ELBOW LONG PERCH FOR C4E/NTU SENSOR (2955 mm, ELBOWED SHUTTER)

- **Straight long pole with elbowed shutter**

PF-ACC-C-00263	STRAIGHT LONG POLE FOR OPTOD SENSOR (2745 mm, ELBOWED SHUTTER)
PF-ACC-C-00264	STRAIGHT LONG POLE FOR PHEHT SENSOR (2745 mm, ELBOWED SHUTTER)
PF-ACC-C-00265	STRAIGHT LONG POLE FOR C4E/NTU SENSOR (2745 mm, ELBOWED SHUTTER)

➤ **Mounting accessories for pole.**

The elements of fixation for the poles are flexible and specially studied to adapt themselves to the different configurations of assembly.

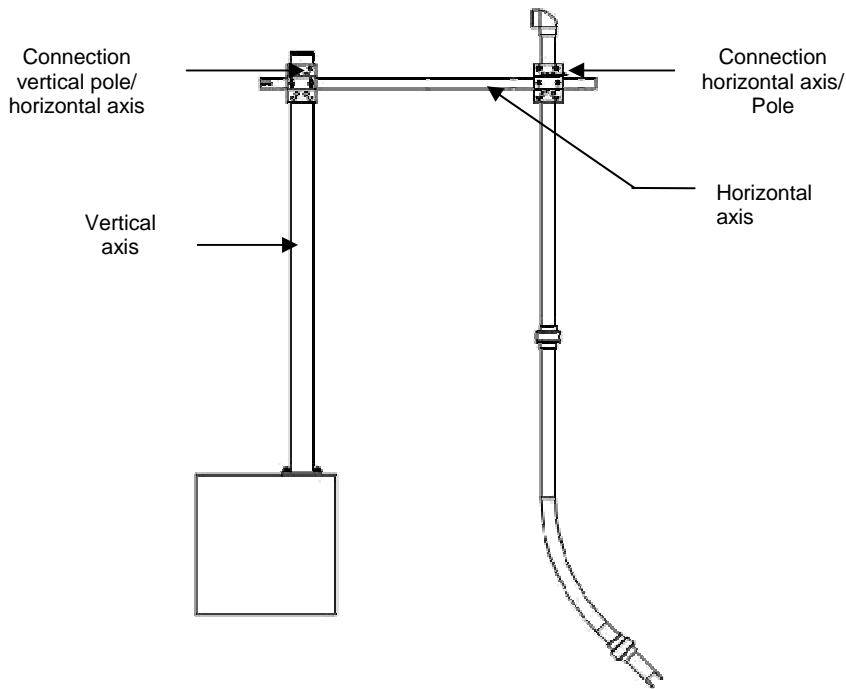

- Pole kit fixation

NC-ACC-C-00009	POLE FIXATION KIT FOR NUMERICAL SENSOR (ON LOW WALL)
NC-ACC-C-00010	POLE FIXATION KIT FOR NUMERICAL SENSOR (ON LIFE LINE)
NC-ACC-C-00011	POLE FIXATION KIT FOR NUMERICAL SENSOR (ON VERTICAL AXIS)
PF-ACC-C-00272	VERTICAL AXIS FOR NUMERICAL SENSOR POLE (TO BE FIXED ON SOIL)

Example of mounting on vertical axis

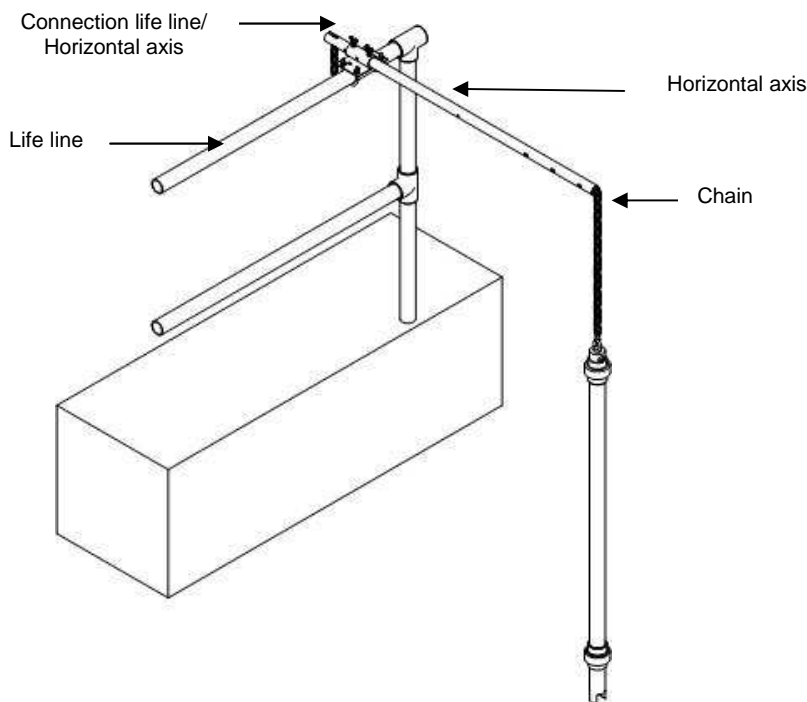

Example of mounting on life line

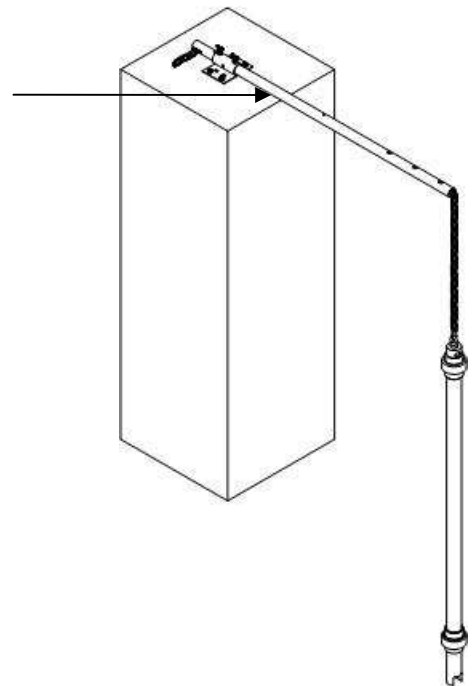

Example of mounting on low wall

- Accessories kit for assembly of poles with chain.

NC-ACC-C-00012	SHORT POLE FIXATION KIT FOR NUMERICAL SENSOR (ON LOW WALL)
NC-ACC-C-00013	SHORT POLE FIXATION KIT FOR NUMERICAL SENSOR (ON LIFE LINE)
NC-ACC-C-00014	SHORT POLE FIXATION KIT FOR NUMERICAL SENSOR (ON VERTICAL AXIS)

4.1.2 Accessories for PVC pipe-mounting

Every system of assembly is delivered with an adapter (and the appropriate joints) and one T of assembly (90 ° for NTU sensor) to stick on a 50 mm diameter pipe. Its special design type ensures the correct inflow to the sensor, thus preventing incorrect measurements.

Please note the following when planning your piping set-up:

- The fitting must be easily accessible to allow the sensor or the fitting itself to be maintained and cleaned regularly
- We recommend bypass measurements. It must be possible to remove the sensor through the use of shut-off valves
- When working with systems involving pressure and/or temperature, ensure that the fitting and sensor meet all relevant requirements
- The system designer must check that the materials in the fitting and sensor are suitable for the measurement (chemical compatibility, for instance)

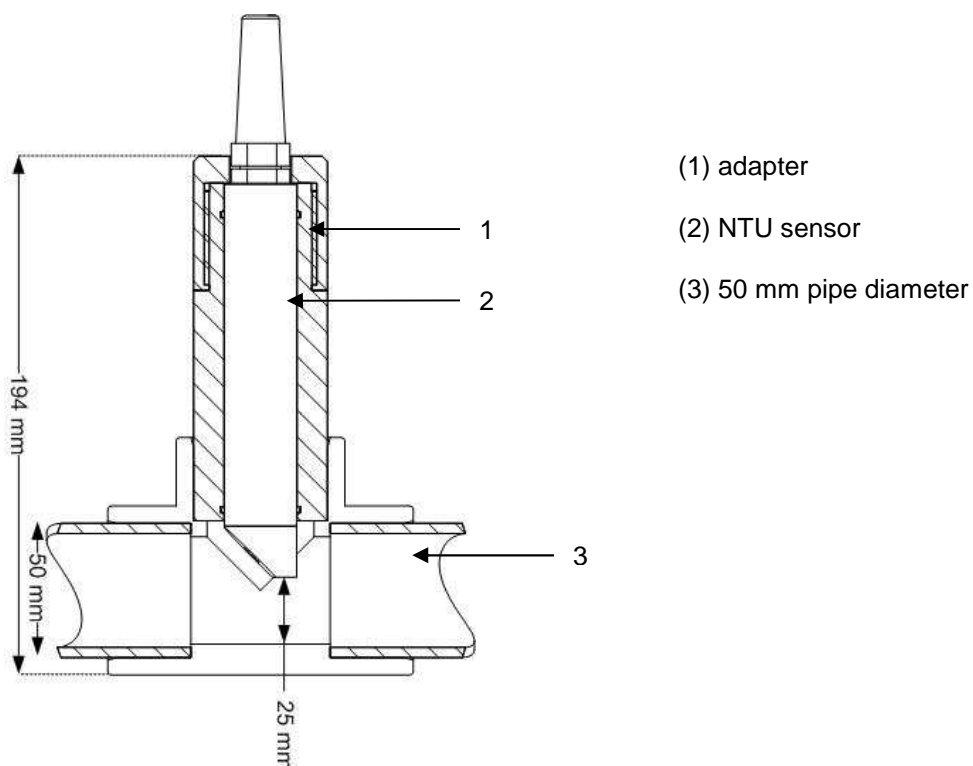

Mounting system for PHEHT sensor (PF-ACC-C-00226)

4.1.3 Accessories for stainless steel pipe-mounting

The accessories of assembly for stainless pipe are proposed with an adapter and its joints with or without the systems of clamp / Nipple. The acceptable maximum pressure for the sensors is 5 bars.

The system of assembly can be delivered with or without stainless steel clamp.

The adapter is compatible with a 51 mm diameter external clamp

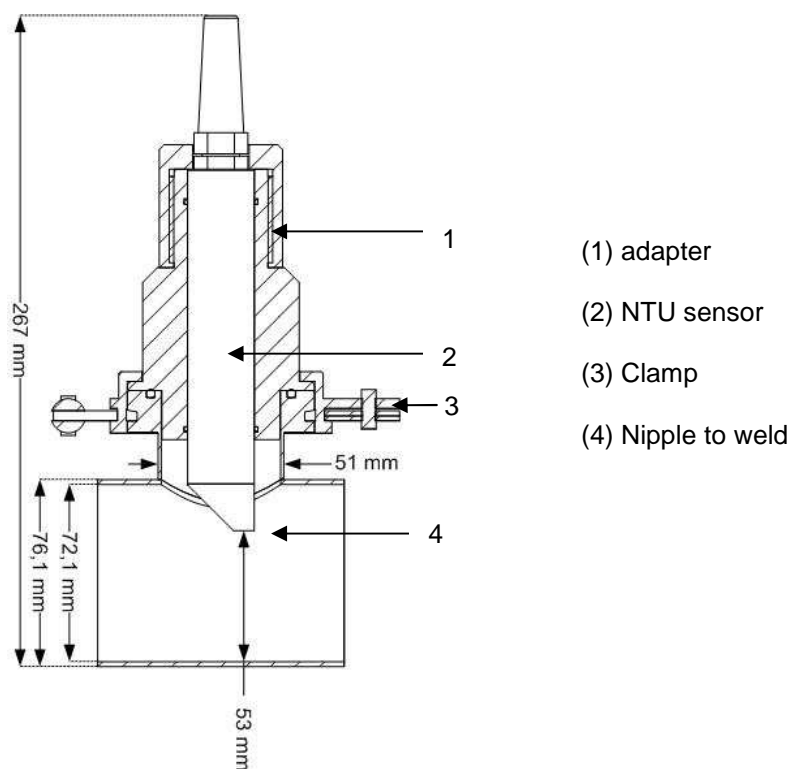

Mounting system for PHEHT sensor (PF-ACC-C-00229)

4.2 Installation of the sensor in the accessories of assembly

4.2.1 Insertion in a pole.

The sensor is mounted on the relevant fitting as described below, using a sensor holder, which can be used both for the short and long pole:

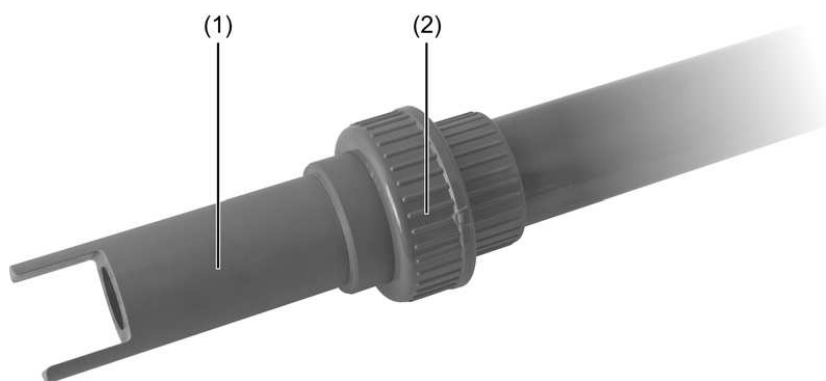

1. Unscrew the union nut (2) of the sensor holder (1) and remove the sensor holder.

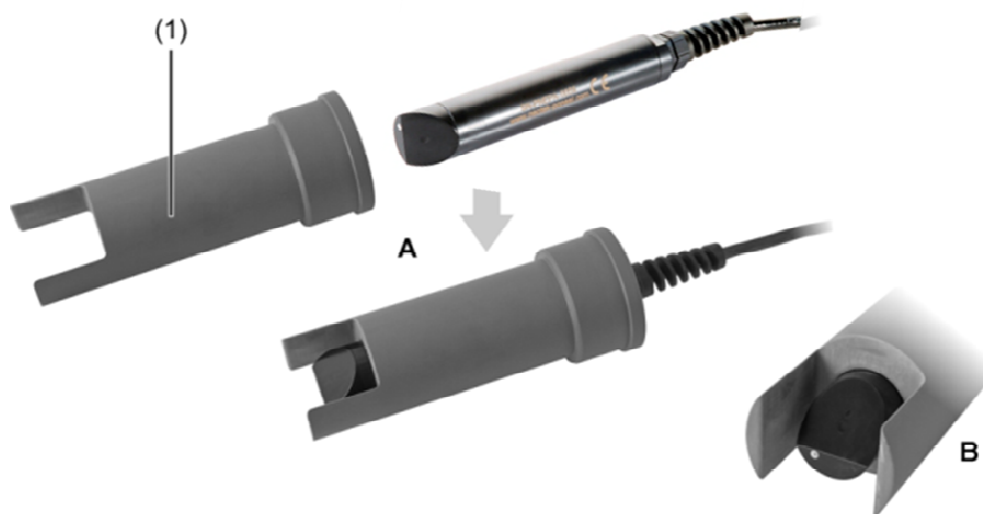

1. Insert the sensor with locking ring (2) into the sensor holder (1) as far as the stop; see Figure **A**.
2. Align the surface of the optical windows in the sensor holder by turning the sensor; see Figure **B**.

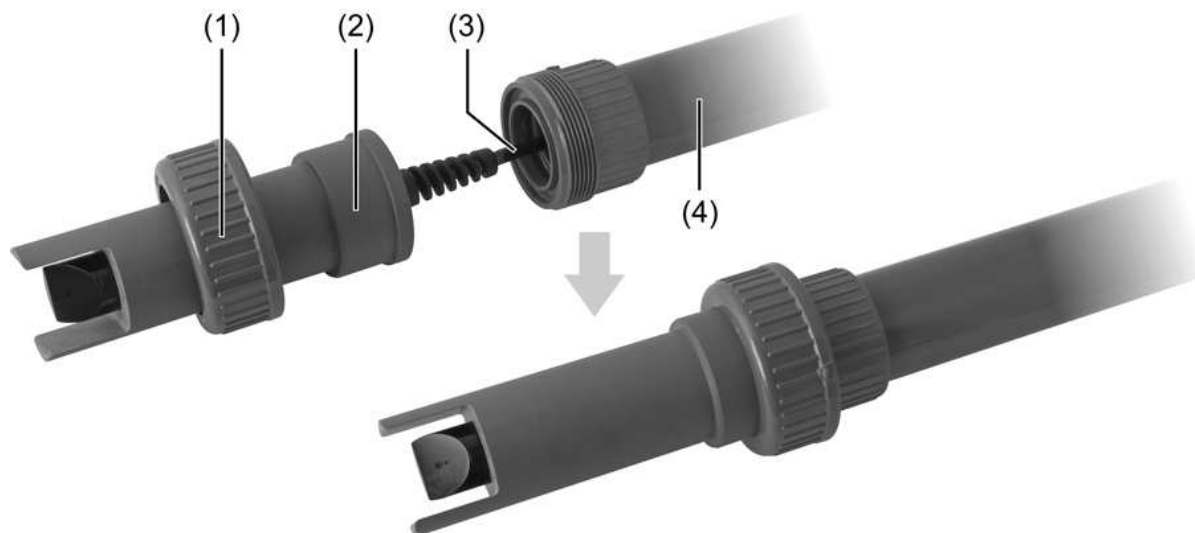

1. Push the connecting cable of the sensor (3) through the fitting (4).
2. Fasten the sensor holder with the sensor (2), as shown in the figure above, to the fitting with the help of the union nut.

The fitting can now be suspended or mounted at the operating location.

4.2.2 Insertion into the PVC in-pipe mounting system.

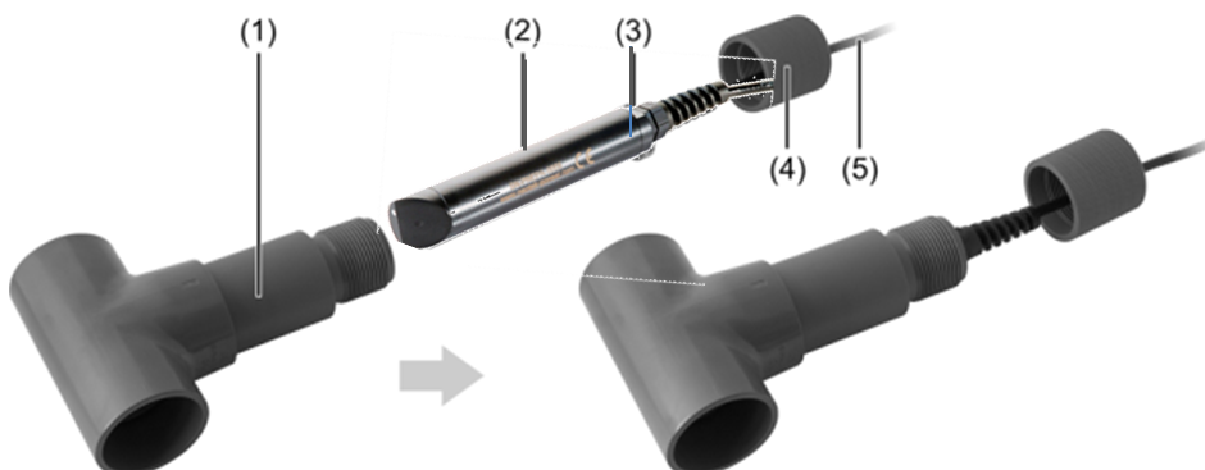

1. Guide the sensor cable (5) through the union nut on the fitting.
2. Push the sensor with the mounted locking ring into the flow fitting as far as the stop. **Pay attention to the alignment of the sensor with regard to the flow/.**
For operation in media with low turbidity, it is recommended to align the optical windows of the sensor perpendicular to the flow (arrow).

For operation in media with relatively high turbidity, the optical windows of the sensors should be turned away from the flow (arrow).

3. Screw the union nut onto the fitting as far as the stop.

4.2.3 Insertion into the Stainless steel in-pipe mounting system.

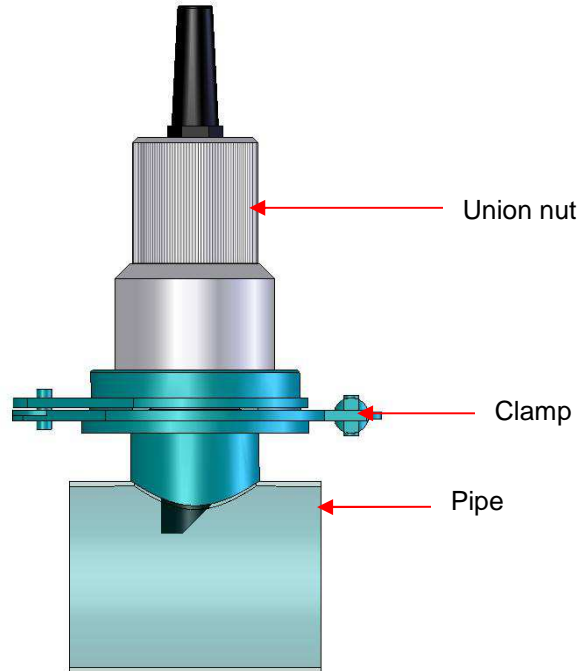

1 After welding the clamp on the stainless steel pipe, remove the clamp from the system and remove the PVC adapter.

2 Unscrew the union nut from the adapter.

3 Guide the sensor cable through the union nut on the adapter and insert the sensor with the mounted locking ring into the flow fitting as far as the stop

Pay attention to the alignment of the sensor with regard to the flow/.

For operation in media with low turbidity, it is recommended to align the optical windows of the sensor perpendicular to the flow (arrow).

For operation in media with relatively high turbidity, the optical windows of the sensors should be turned away from the flow (arrow).

4 Reposition the adapter in the nipple, and re-screw the union nut.

4.3 Electrical connections.

The sensor could deliver within version bare wire on 3, 7, 15 m or on other length (up to 100 m).

Power supply	
Power requirements	5 to 12 volts for cable 0-15 m 7 to 12 volts for cable >15 m Max. 13.2 V
Consumption	Standby : 40 μ A Average RS485 (1 measure/seconde) : 820 μ A Average SDI12 (1 measure/seconde) : 4,2 mA Current pulse : 500 mA Heating time : 100 mS Protection against the inversions of polarity

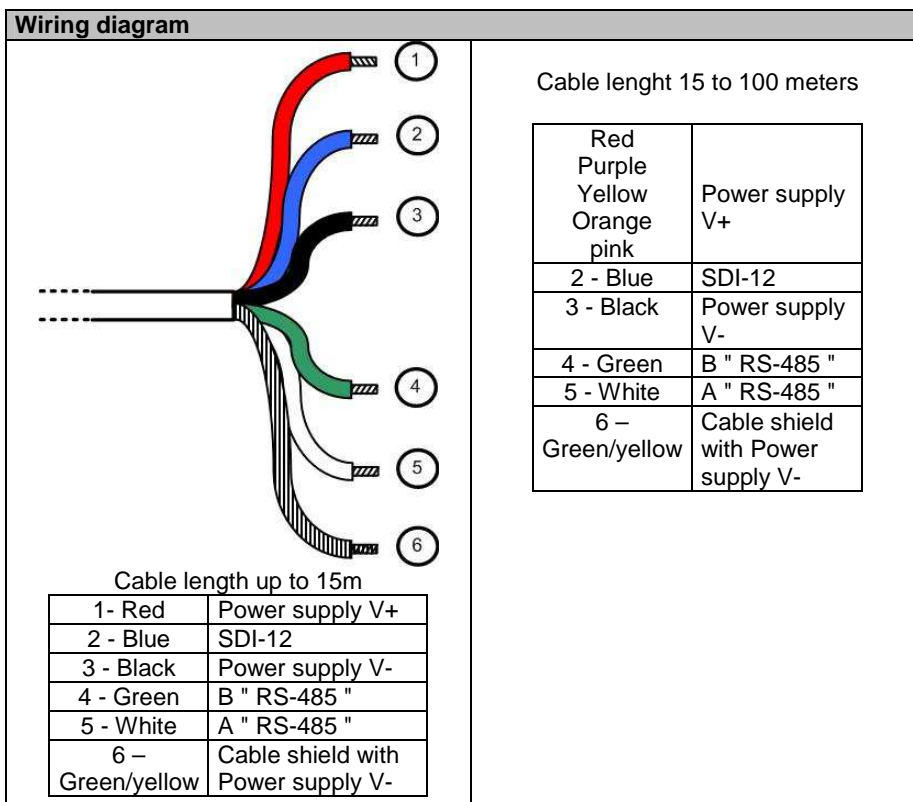

5. Startup and maintenance.

5.1 Initial startup

Once the sensor is connected to your terminal, the sensor is settled in its accessory of assembly and the parameterization has been carried out on the display unit, the sensor is ready for initial startup.

➤ **Note :**

For measurement, you must eliminate bubbles trapped under the optical window.

During the introduction of the sensor in measurement environment, wait for sensor's temperature stabilization before measure processing.



The optical windows are vulnerable to:

- chemicals (organic solvents, acids and strong bases, peroxide, hydrocarbons),
- mechanical treatments (impact, abrasion).

➤ **Started :**

Remove the black cap of protection (by holding the sensor head downward and by unscrewing the hood towards the right).

5.2 Calibration

The method of **two-point calibration for each of the four measuring ranges** is available for calibrating the sensor.

The sensor should be rinsed with clean water before each calibration. Organic deposits left on the sensor lens, such as a biofilm or silt, may cause measurement errors. These deposits should be removed carefully with warm soapy water and a soft sponge. Never use abrasive agents (e.g. scouring sponge).

Calcium deposits can be removed by submersing the sensors in a diluted hydrochloric acid solution (**concentration max. 5 %**) for several minutes.

5.2.1. Calibration in NTU

The sensor is calibrated ex works, meaning that no calibration is required before initial startup. During operation, the sensor should be calibrated if the measured values begin to drift. If the zero point is moved, a complete two-point calibration must be carried out.

5.2.1.1 Offset calibration

The NTU sensor is an optical sensor which just need of a few calibration. On a clean sensor, check once in a while the 0 NTU value by dipping sensor in bubble free clear water. If the 0 point is shifted, proceed with the complete sensor calibration (on 1 or 4 ranges).

It is carried out as follows:

- Immerse the sensor in distilled water (Attention on side effects, sensor has to be for a distance > 5 cm with regard to walls) in order to determine the zero point (offset). Wait that the sensor puts itself in equilibrium with the temperature of the standard solution.
- Drying the sensor with a soft cloth or an absorbent paper.

5.2.1.2. Slope calibration.

- Sensor slope is determined by positioning the sensor in a Formazine solution which depends of the calibrated range.

For this procedure, a Formazin solution, with concentration matching the middle of the measurement range, will be necessary. This solution will be prepared from a 4000 NTU main solution.

For the preparation of solutions, take a flask of 200 mL. Introduce the necessary volume of Formazin (cf. table below) and fill up to 200 mL with distilled water.

The formazin solutions of concentrations lower at 1000 NTU deteriorate quickly, so do not preserve a solution during several days.

The solution at 2000 NTU can be preserve in the refrigerator for 2 or 3 weeks in a opaque flask.

Measurement range	Concentration Formazin solution	Volume of Formazin (mL)
0.0-50.0 NTU	25 NTU	1,25 mL
0.0-200.0 NTU	100 NTU	5 mL
0-1000 NTU	500 NTU	25 mL
0-4000 NTU	2000 NTU	100 mL

Immerse the sensor in the selected standard solution, maintain the standard solution under agitation and wait that the sensor puts itself in equilibrium with the temperature of the standard solution.

- Rinse the sensor in clean water and drying the sensor with a soft cloth or an absorbent paper.

5.2.2. Calibration in mg/L

5.2.2.1 Offset calibration

It is carried out as follows:

- Immerse the sensor in distilled water (Attention on side effects, sensor has to be for a distance > 5 cm with regard to walls) in order to determine the zero point (offset). Wait that the sensor puts itself in equilibrium with the temperature of the standard solution.
- Drying the sensor with a soft cloth or an absorbent paper.

5.2.2.2. Slope calibration.

Turbidity in mg / L, it is necessary to calibrate the sensor on a real sample.

Immerse the sensor into a sample of sludge, maintained under agitation, and validate the theoretical value measured by the sensor. Analyse the sample dry weight in the laboratory according to the NF standard IN 872 for a range of 0-500 mg / L and according to the NF standard T 90 105 2 for a concentration > 500 mg / L.

5.3 Maintenance

The following points should be taken into account during ongoing operation of the sensor:

- The sensor must always be kept clean, particularly in the area around the optical windows. The presence of deposits on the optical windows may lead to measurement errors.
- Deposits such as a biofilm or silt should be removed carefully with warm soapy water and a soft sponge. Never use abrasive agents (e.g. scouring sponge).
- If the sensor is put out of operation, it should be rinsed ready for storage, and the provided protective cap should be fitted.

AQUALABO CONTROLE After-Sales Service

AQUALABO CONTROLE
35 Rue Michel MARION
56850 CAUDAN
FRANCE

Tel.: +33 (0)1 72 87 97 93
Email: sav.ponsel@aqualabo.fr